

Scaffold Tool & Training Company

Garnsworthy Square
46, 62 & 64 Garnsworthy St
Springvale North
Victoria
3171

Web: www.thescaffoldco.com.au
Web: scaffoldtrainingcompany.com.au
Email: enquiries@scaffoldco.com.au
Phone: 1300 551 610 Facsimile: (03) 9547 8889



Updated on 21/02/08
STC 402

Name _____

FORKLIFT KNOWLEDGE QUESTIONS

Helping you get it right

THE PROFESSIONALS IN SCAFFOLD TRAINING

Couplers
Scaffold Belts
Scaffold Tools
Steel Scaffold Sales
Scaffolding Pouches
Aluminum Scaffold Sales
Forklift & EWP Operation
Scaffold Maintenance & Repairs
Basic, Intermediate & Advanced Scaffolding Training & Assessment

THE PROFESSIONALS IN SCAFFOLD TRAINING

CONDUCTS ROUTINE CHECKS: UNIT 1

Element 1.1 (select 7 including 2 with a star)

1. You are required to inspect your forklift truck before use. Name at least four liquid levels that would form part of your inspection?

2. You are required to inspect your forklift truck before use. Name at least four parts which would form part of your inspection?

3. What precautions should be taken by the operator when a leak in the fuel system is suspected or detected?



4. During your pre operational check a hydraulic leak is detected. What action would you take?

5. During your pre operational check you notice the Data Plate is missing or unreadable. What action would you take?



6. Under what circumstances could an operator make minor repairs, alterations or adjustments to a forklift truck?

7. If you noticed a crack in the heel of a fork arm would you try and repair it yourself?

8. A tyre is found to have low pressure. When would you attend to this problem?

9. What important function does a load backrest (load guard) perform on a forklift truck?

THE PROFESSIONALS IN SCAFFOLD TRAINING

10. To protect the operator from falling objects, what should be provided on a forklift truck?

15. Why is it unsafe to turn a forklift truck when it is on a ramp or sloping surface? 

Element 1.2 (select 25 including the 18 with a star)

11. Should a forklift truck be refuelled while the engine is running? Explain your answer. 

16. When operating a forklift why is it dangerous to turn a corner with the load raised? 

12. What direction must the load Face when travelling up a ramp? 

17. How should you drive a forklift truck across railway tracks?

13. When travelling up a ramp, why must the load face uphill?

18. When travelling, at what height should the load and fork arms be? 

14. What direction must the load Face when travelling down a ramp? 

19. When travelling name two items / conditions that would influence your speed of travel.

THE PROFESSIONALS IN SCAFFOLD TRAINING

20. A pallet contains an unbalanced load with one end heavier than the other. Which end should be against the heel of the fork arms? 

21. What would you do if you noticed a badly damaged pallet supporting a load?

22. How should bagged goods be transported and stored?

23. What is the minimum distance you should keep your forklift truck and load away from domestic powerlines and high voltage transmission lines? 

24. What would you do if you drove your forklift truck mast into powerlines? List three actions.

25. Why is it dangerous to use internal combustion engines in confined spaces? 

26. What is the most suitable type of forklift truck to use in confined spaces?

27. Why must batteries be charged in a well ventilated area?

28. Why must you not smoke when charging or changing forklift truck batteries? 

29. What type of forklift truck should be selected for working on rough or unstable terrain?

THE PROFESSIONALS IN SCAFFOLD TRAINING

30. What is meant by “collapsed height” in relation to a forklift truck?

31. What is meant by “overall extended height” in relation to a forklift truck?

32. When travelling with a large load that obscures your vision, what precautions would you take?

33. What should be provided when a forklift truck is working over a roadway, footpath or areas open to the public? 

34. Name two safeguards to protect other personnel when loads are moved by a forklift truck 

35. Why is “rear end” swing dangerous on forklift trucks fitted with rear end steering? 

36. Why is a work permit to operate a forklift truck necessary at some work sites?

37. May a load be carried by only one fork arm of the forklift truck? Explain your answer.

38. Are you allowed to add additional counterweights to a forklift truck without referring to the forklift manufacturer? Explain your answer.

39. What precautions should the operator take when operating the forklift truck on wet or slippery surfaces? 

40. What checks must be made before using an attachment on a forklift truck? 

THE PROFESSIONALS IN SCAFFOLD TRAINING

41. If you are required to use an attachment that you are not familiar with, what should you do?

42. Name three operating precautions that must be taken when using a jib attachment?

43. Is it permissible to use the forward tilt when lifting loads with a jib attachment? Explain your answer.

44. What must be marked at each hook position on a jib attachment?

45. When operating a forklift fitted with a carpet spike, what precautions would you take?

46. Why should a side-shift attachment be centralised before travelling with a load?

47. When using a revolving attachment is it permissible to rotate the load while travelling? Explain your answer

48. What should be used to carry drums with a forklift truck?

49. What must a lifting ring and the slings attached to it have in common?

50. Should a jib attachment, lifting hook be fixed or able to swivel?

51. For what reason must you ensure that a jib attachment hook is centred directly over a load before lifting?

THE PROFESSIONALS IN SCAFFOLD TRAINING

52. When should slings be inspected?

53. When inspecting wire rope slings, list five defects that would render the sling unsafe to use?

54. How would you determine the working load limit (WLL) for synthetic webbing slings?

55. Why is it important to secure the pin in a shackle?

56. What percentage of wear in a shackle would make it unsafe to use?

57. How would you determine the Safe Working Load of a multi-leg chain sling?

58. Should a load be raised or lowered near or over people? Explain your answer.

59. What must be provided on a fork lift truck to allow a passenger to be carried?

60. Is it permissible to carry passengers on the bare fork arms or load? Explain your answer.

61. By what means can people be raised on a forklift truck?

62. When using a Work Platform to lift people, what position must the travel controls be in, and in what position must the parking brake be?

THE PROFESSIONALS IN SCAFFOLD TRAINING

63. Where must the operator of a forklift remain when a person is raised in a Work Platform?

68. Why is tyre pressure, and condition for pneumatic types, important to the stability of a forklift truck?

64. Is a stepladder or other device allowed to be used to gain extra height whilst working from a Work Platform?

UNIT 2 Element 2.1 (Select 13 including 9 with a star)

69. Because of load length, two forklift trucks are used to handle the same load (simultaneous use). Name any three operating precautions that must be observed.

65. On an electric forklift what would you use to isolate the power supply in an emergency?

70. How would you establish the capacity and limitations of the forklift truck and equipment you are required to use?

Element 1.3 (select 2)

66. Give reasons why preoperational checks are necessary before operating a forklift truck.

71. What is meant by the term "Rated Capacity" in relation to a forklift truck?

67. If any defects are found or detected what must you do?

THE PROFESSIONALS IN SCAFFOLD TRAINING

72. What is meant by load centre distance? 

73. How does increasing the load centre affect the capacity of a forklift truck? 

74. How will a forklift truck be affected if the load is not hard against the heel of the fork arms? 

75. Where is the forward Point of Balance (fulcrum) for a forklift truck? 

76. Is all the weight behind the Point of Balance acting as a counter-weight? 

77. The forklift trucks in Attachment A are rated at 2000 kg at 600 mm load centre, which one is overloaded? 

78. A forklift truck in Attachment B is rated at 4500 kg at 600 mm load centre. Which of the loads are within the capacity of the forklift truck? 

79. Give two reasons why you check the weight of a load against the forklift truck specifications. 

80. How would you determine the weight of an unmarked load? 

81. What is the approximate mass (weight) of a 200 Litre (44 gallon) drum full of water? 

THE PROFESSIONALS IN SCAFFOLD TRAINING

82. How many Kilograms are there in 1 Tonne?

83. What things should be considered when tiering (stacking) loads on top of each other?

84. When should forward tilt of the mast be used?

85. A pallet appears to be unsafely loaded. What would you do before attempting to lift it?

86. Name three operating conditions that may cause a forklift truck to tip over sideways? (lateral instability)

87. Name three operating conditions that may cause a forklift truck to tip forward length- ways? (longitudinal instability)

88. What should be provided for the gap between a truck and a loading dock before shifting a load?

89. Which vehicles must you give right of way to during emergency situations?

UNIT- 3 Element 3.1 (Select 5 including 1 with a star)

90. Name three locations within the workplace where you would not park your forklift truck.

91. Why would you not park your forklift in front of a doorway?

THE PROFESSIONALS IN SCAFFOLD TRAINING

92. If your forklift truck must be parked on an inclined surface, what precaution would you take?

97. What is the reason for removing the ignition key when leaving the forklift truck unattended?

93. When parking your forklift truck what must be done with the fork arms?

94. Why do you turn off the LPG Fuel valve after parking and before leaving your forklift truck?

95. Give 3 reasons why post operational checks are carried out on a forklift?

96. Whilst carrying out a post operational check, you notice a fault, what do you do before leaving the forklift?

ATTACHMENT A

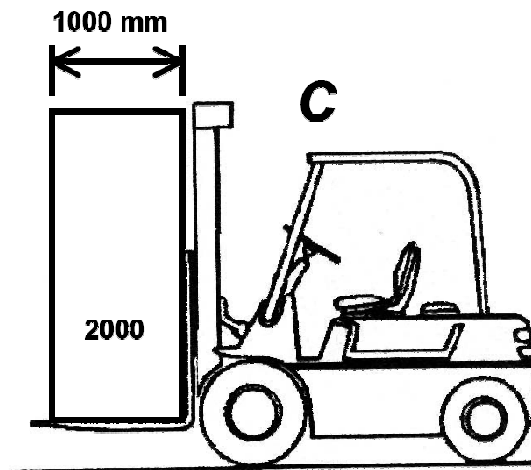
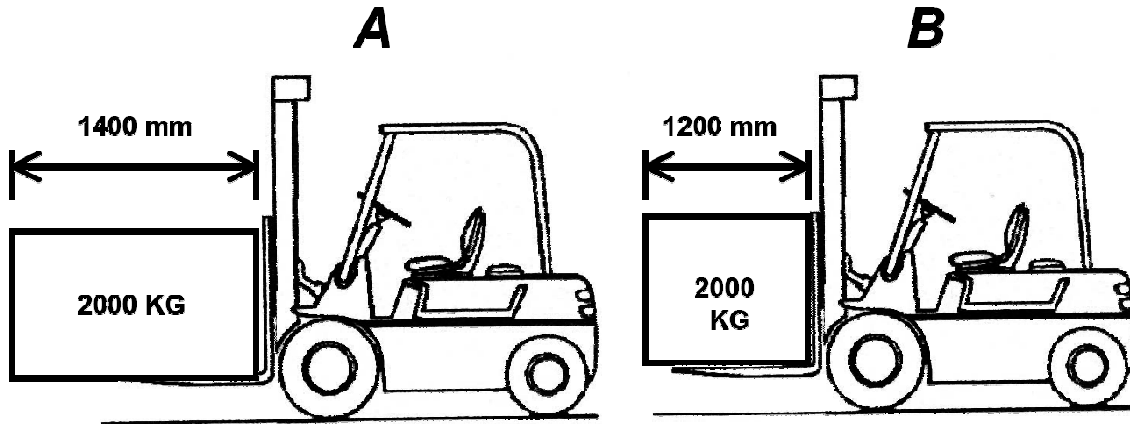

ATTACHMENT B

